



Vertical and horizontal freezers WHALE 1500G-1500NP



Epta S.p.A. participates in the ECC programme for:
 Refrigerated display cabinets (RDC). Check ongoing validity
 of certificate online: www.eurovent-certification.com
 or using: www.certiflash.com

Product categories



Technical features





WHALE 1500G-1500NP		
Length mm		2500 3750
WHALE 1500G-1500NP		• •
Display area m2		3.10 4.65
Loading area m2		3.76 5.64
Net storage capacity dm3		967.00 1450.00
End thickness mm	Panoramic	70 (+ 104)
	Blind	51 (+ 104)



WHALE 1500NP

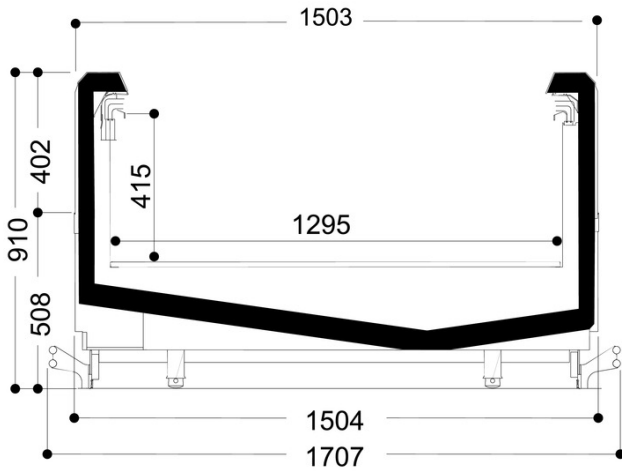

WHALE 1500G

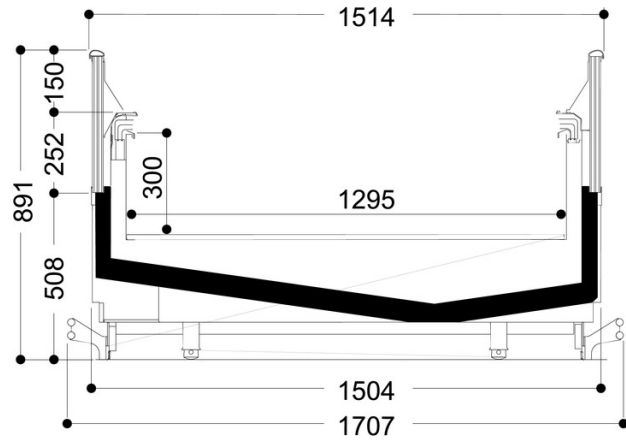



Legend

 Meat	 Chicken	 Fish	 Pre-packed fish
 Delicatessen	 Cheese	 Dairy products	 Gastronomy
 Pastries	 Pre-packed fruit and vegetables	 Fruits and Vegetables	 Sandwiches
 Drinks	 Pizza	 Bread	 Frozen food and ice cream
 Off-cycle defrost	 Electric defrost	 Hot-gas defrosting system	 Manual defrost
 Ventilated	 Static	 Incorporated condensing unit	 Remote condensing unit
 Bagnomaria	 Ceramic glass	 Ice	 VSD Inverter technology
 LED lighting	 Zero C doors	 High efficiency fans	 R290 Propane refrigerant gas (R290)
 R134a R-134a - 400V/3PH/50Hz	 R404A R404A - 400V/3PH/50Hz	 R744 R744 - 400V/PH/50Hz	 Compressor hermetic reciprocating
 Hermetic scroll compressor	 Semi-hermetic reciprocating compressor	 VSD Inverter technology	 External installation
 Machinery room	 Soundproof housing	 On board condenser	 Remote condenser
 DUAL Medium & Low temperature			